

# PERMANENT REFERENCE ELECTRODES

## SELECTION GUIDE



ONSHORE

ELECTRODES							
Cu/CuSO <sub>4</sub> (liquid) soil	Zn 99.99% (solid) soil	Zn 99.99% (solid) water	Ag/AgCl (solid) water	MnO <sub>2</sub> steel in concrete	Polarization probe	Test coupon	Supporting structure Weld-in flange
<input checked="" type="checkbox"/>	<input checked="" type="checkbox"/>				<input checked="" type="checkbox"/>	<input checked="" type="checkbox"/>	
		<input checked="" type="checkbox"/>	<input checked="" type="checkbox"/>				<input checked="" type="checkbox"/>
		<input checked="" type="checkbox"/>	<input checked="" type="checkbox"/>				<input checked="" type="checkbox"/>
				<input checked="" type="checkbox"/>			



OFFSHORE



INTERNAL



STEEL REBARS IN CONCRETE

Supporting structures required for the installation of electrodes can be supplied as an optional item on request

**PERMANENT REFERENCE ELECTRODES**  
**Cu/CuSO<sub>4</sub> and Ag/AgCl**

Document No.: 07-100-R2  
 Sheet: 1 of 1

German Cathodic Protection



**Type: Cu-PRE (Cu/CuSO<sub>4</sub>)**

Permanent reference electrode with a special, porous terracotta pot that allows humidity absorption from ground. This ensures that the copper sulfate solution inside the electrode remains saturated. With 1.130 cm<sup>2</sup> of exposed surface, the copper wire spiral ensures constant reading even under difficult operating conditions.

**Properties**

- Simple installation
- Service lifetime: min. 10 years  
(depending on local soil conditions and service)
- Excellent performance

**Note:**

In very dry or resistive ground, we recommend installing the electrode in bentonite bedding.

**GENERAL ASSEMBLY**

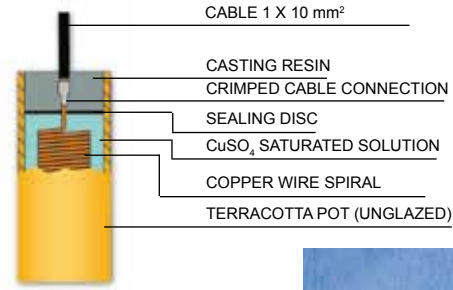

Potential referring to H <sub>2</sub> - electrode	+0.32 V
Temperature range	-10° - +50° C
Variation of potential, approx.	+0.9 mV / °C
Outside pot dimensions (mm)	D=150 , H=300
Weight, approx.	8.5 kg
The electrode can be delivered in a cotton bag surrounded of chemical backfill	50 % Gypsum 40 % Bentonite 10 % Salt
Max. dimensions of prepacked electrodes including cotton bag and backfill	Diameter: 200 mm Height: 450 mm Weight: 15 kg

Reference electrode available with 5 m HEPR/PVC or (XLPE/PVC) 1 x 10 mm<sup>2</sup> cable

**Type: Ag-W (Ag/AGCl)**

**Application**

Reference electrode Ag-W designed for use internally protected steel water containers, tanks, pipes, etc. and is supplied with a 1 inch screw-in thread for permanent fixture using a weld-in flange.

The measuring cell is contained inside a plastic tube with 2 holes on the lower side and 1 hole in the base for electrolytical contact to water.

Potential referring to H <sub>2</sub> - electrode	+ 0.25 V
Temperature range	acc. to Purchaser requirements
Operational pressure	acc. to Purchaser requirements
Length of measuring electrode X	acc. to Purchaser requirements
Cable type and length	acc. to Purchaser requirements

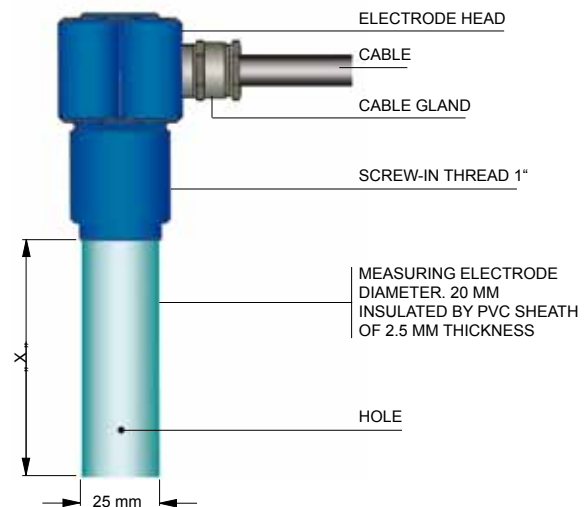

**PERMANENT REFERENCE ELECTRODES**

**Zn 99.99 % (Solid)**

Document No.: 07-200-R2

Sheet: 1 of 1

**German Cathodic Protection**



**Type: Zn-U (Zn 99.99 %)  
for Permanent Underground Application**

Reference electrode Zn-U is prepacked in a cotton bag filled with non-polarizing bentonite backfill.

Potential referring to H <sub>2</sub> - electrode	- 0.77 V
Temperature range	0 - 55° C
Composition of backfill	75 % Gypsum 20 % Bentonite 5 % Salt
Cotton bag dimensions	Diameter: 100 mm Height: 220 mm Weight: 3.6 kg*

\* with a cable length of 5 m

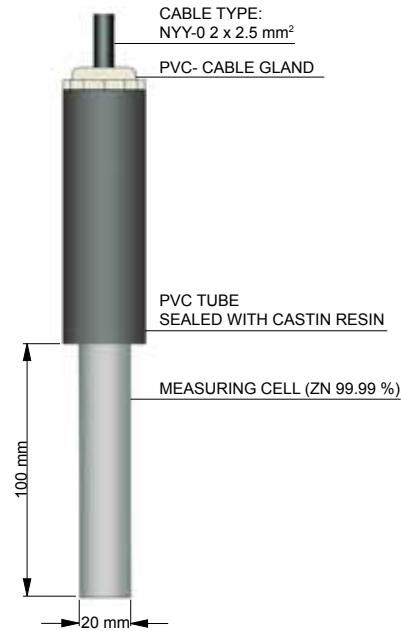

**Type: Zn-W (Zn 99.99 %)**

**Application**

Reference electrode Zn-W is used inside internally protected steel water containers, tanks, pipes etc. and is provided with a 1" screw-in thread for permanent fixture by using a weld-in flange. The measuring cell is covered with insulating material so that the only exposed area is the circular base at the bottom.

Potential referring to H<sub>2</sub> - electrode: - 0.77 V

Temperature range, Operational pressure, Length of measuring electrode „X,, and Cable type and length according to Purchaser requirements.

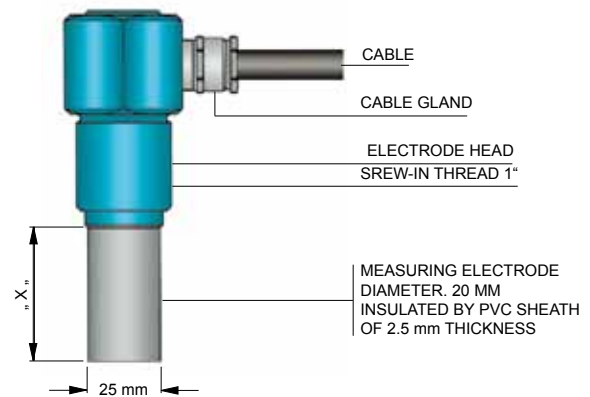

**Type: Zn-SW (Zn 99.99 %)**

**Application**

Reference electrode Zn-SW is used dipped in freshwater or seawater

Potential referring to H<sub>2</sub> - electrode: - 0.77 V

CABLE TYPE: NYY-0 2 x 2.5 mm<sup>2</sup>

Cable length according to Purchaser requirements.

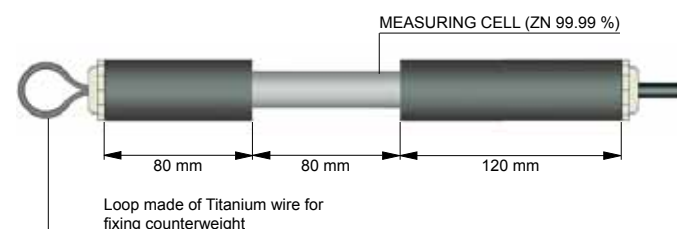

**Polarisation Probes**

**General**

The polarization probe is used where an appreciable voltage drop ( IR - drop ) in the soil is present. This is due to the flow of current in interconnected, protected pipelines or objects or due to galvanic currents or stray currents, because of contacts between steel/concrete and steel/soil in industrial plants.

The probe is buried close to a pipeline, in the same soil and connected to a test station.

Type: GCP-PB 1.0 Test surface area: 1.0 cm<sup>2</sup>  
 For protective objects with very small areas of coating damages like: well coated pipelines

Type: GCP-PB 10.0 Test surface area: 10.0 cm<sup>2</sup>  
 For protective objects with small areas of coating damages like: bad coated pipelines or plant areas etc.

Type: GCP-PB 72.0 Test surface area: 72.0 cm<sup>2</sup>  
 For protective objects with large areas of coating damages like: very bad coated pipelines or plant areas etc.



Housing	PVC
Reference electrode	Zn 99.99 %
Potential referring to H <sub>2</sub> - electrode	-0.77 V
Temperature range	0° C to 55° C
Test surface material	Steel
Connecting cable	NY Y-0 4 x 2.5 mm <sup>2</sup>

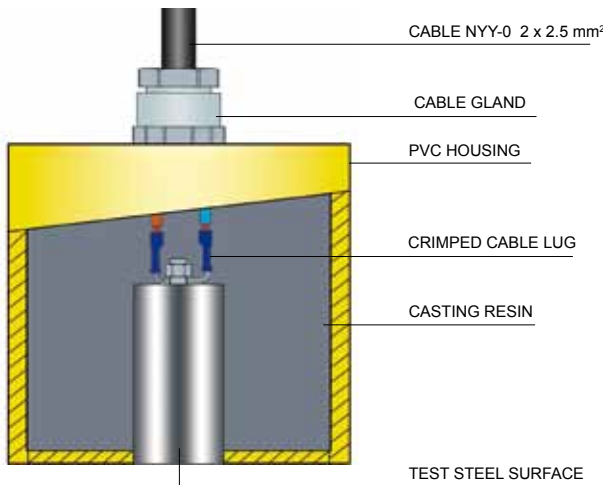

Type: GCP-TC 1.0 Test surface area: 1.0 cm<sup>2</sup>  
 For protective objects with very small areas of coating damages like: well coated pipelines

Type: GCP-TC 5.0 Test surface area: 5.0 cm<sup>2</sup>  
 For protective objects with small areas of coating damages like: bad coated pipelines or plant areas etc.

Type: GCP-TC 10.0 Test surface area: 10.0 cm<sup>2</sup>  
 For protective objects with large areas of coating damages like: very bad coated pipelines or plant areas etc.

Housing	PVC
Temperature range	0° C to 55° C
Test surface material	Steel
Connecting cable	NY Y-0 2 x 2.5 mm <sup>2</sup>

**Test Coupons**

**General**

Coupons are one of a valuable tool in determining the effectiveness of cathodic protection. Cathodic protection adequacy can be obtained by using coupons of the same metal as that of the protected structure. These are electrically connected to the protected structure. The coupons should be placed where they can receive the same exposure to cathodic protection current as does the structure. In connection with a permanent reference electrode installed close to the test coupon the real polarisation potential of the defined test surface can be determined.



**Embeddable reference electrode for potential reading ( ERE 20 )**



The ERE 20 is a true, long life Reference Electrode, which can be cast into the cover concrete to check the cathodic protection and to monitor the corrosion state of reinforcing steel or predict corrosion. Normally in newly cast concrete structures, but the electrode can also be installed in existing structures.

The potential of ERE 20 is virtually independent of changes in the chemical properties of the concrete. It can, therefore, be used in wet or dry concrete, whether exposed to chlorides or to carbonation.

Based on proven battery technology, the ERE 20 is a true half-cell using a manganese dioxide electrode in steel housing with an alkaline, chloride-free gel. The steel housing is made of a corrosion resistant material. The pH of the gel corresponds to that of pore water in normal concrete, so errors due to diffusion of ions through the porous plug are eliminated.

The ERE 20 can easily be attached to a logger in order to monitor data. Remote monitoring by modem is also possible.

**Advantages**

- Control of cathodic protection
- For potential measurement in wet and dry concrete
- Can be exposed to chloride or carbonation
- Does not induce corrosion in steel
- Does not change potential of steel
- Easy to install in new or old structures



**Example**

The ERE 20 is used to check the correct operation of the cathodic protection in structures. Figure 1 shows a typical curve found on checking a CP-system.

The reinforcing steel to be protected shall be polarised a minimum of 100 mV at anodic locations. When using the polarisation decay method, the decay is determined by interrupting the protective current and monitoring the reinforcement's potential measured relative to a stable reference electrode.

When the current is interrupted, an immediate voltage shift is the result of eliminating the IR-drop and is not to be included in the polarisation measurements.

According to EN 12696 the Polarisation Decay should be met within 24 hours.

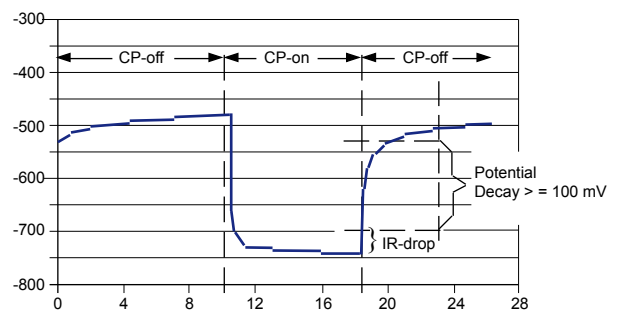

Figure 1: Polarisation curve from CP-system

## CorroWatch Multiprobe

The CorroWatch is a multiprobe, which in the standard version consists of four black steel anodes and one noble metal cathode. The anodes are placed in varying, but defined distances from the exposed concrete surface. The height of the anodes is flexible and can be adjusted according to the concrete cover thickness.

The CorroWatch acts as an early warning system to predict the initial stages of corrosion in concrete structures. It is cast into the cover concrete, normally in newly cast concrete structures. The probe can measure most of the relevant corrosion parameters.

To predict when the reinforcement will start corroding, the current between the single anodes and the cathode is measured, either with a volt-meter or a specially designed data logger. When corrosion starts, the current will increase significantly.

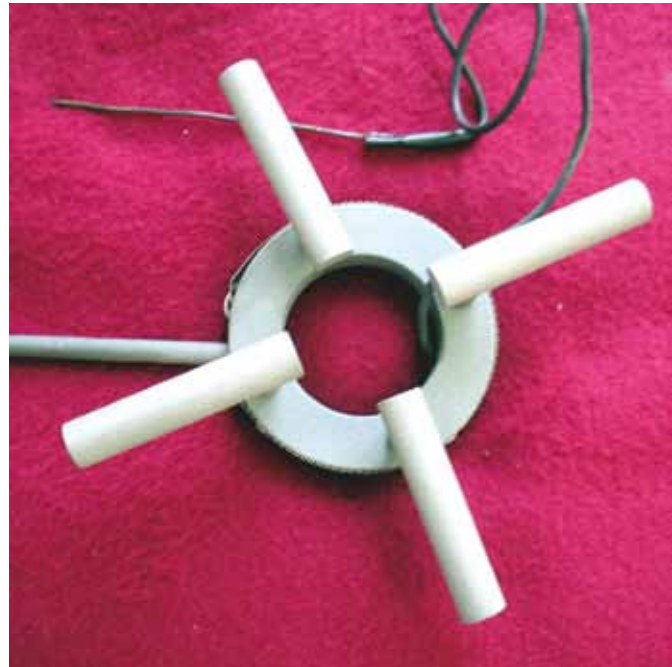

### Areas of use

- Areas difficult to access, e.g. tunnels.
- Bridges in marine environments.
- Splash zones, e.g. pillars in sea water.
- De-icing areas, e.g. parking floors/decks.
- Structures heavily affected by acid rain, e.g. chimneys.

### Example

The adjacent picture shows a CorroWatch multiprobe which has been installed for monitoring of time to corrosion initiation in the immersed elements of a tunnel.

The CorroWatch were installed in such a way that the concrete cover on the highest electrode (anode) is approximately 25 mm.

### Example

In Figure 1 an example from a laboratory test is shown indicating when the corrosion initiates at each of the 4 anodes.

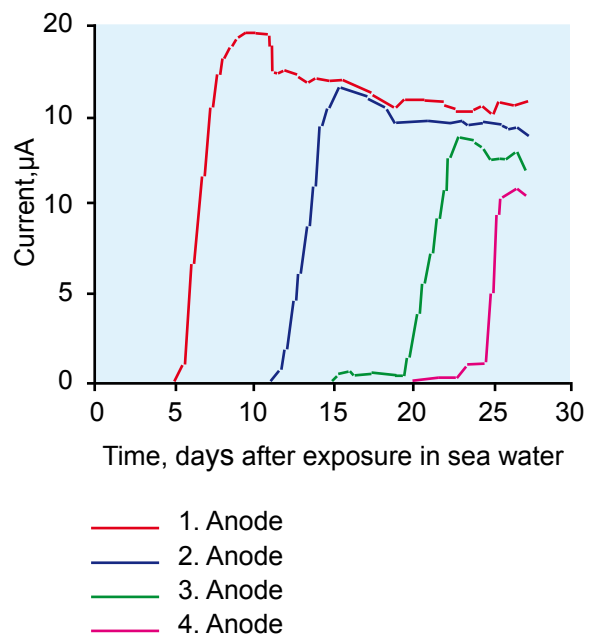

Figure 1. Increase in current in the 4 anodes